



Modular Shelf for MIR100/200 ISH Fixed

We are proud to introduce a new range of products for AGV and Mobile Robots.

Our solutions, sold with the formula "order and assemble by yourself", are supplied with everything necessary, assembly drawing and screws, to simplify and speed up the supply of modular shelving systems for different applications. We can provide customization of products with our Partners' logos. We have many designs in our catalog but we are always available to produce customized solutions.

Fastening the rack to MiR 100 trolley takes place by M8 bolts, which guarantee proper stability and reliability of fastening.

Technical data:

SIDE

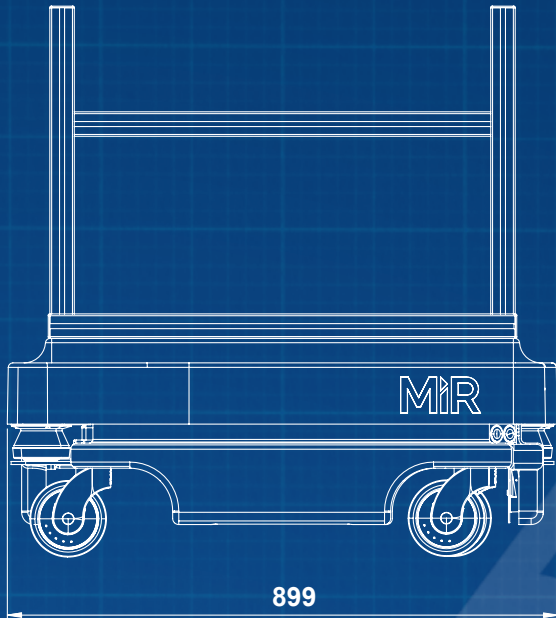

FRONT

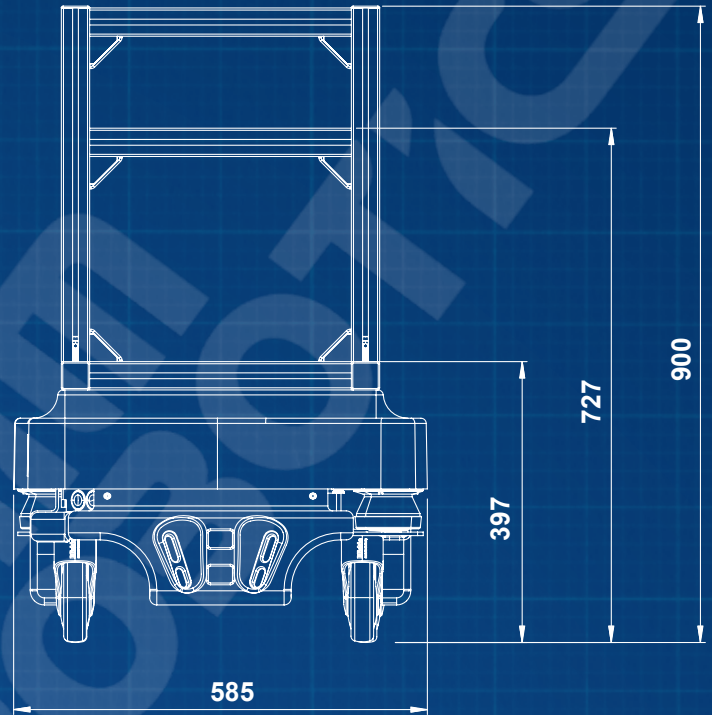

Number of shelves - 2

Weight - 18 kg

Weight with MiR 100 - 79 kg

Maximum weight load on each shelf - 20 kg

Maximum weight load on each shelf when mounted:

- On MiR 100 - 20 kg
- On MiR 200 - 20 kg

Material:

Aluminum

Plastic

Steel

Hardwood plywood

Compatibility:

MiR 100

MiR 200

Dimensions:

Separate / Mount on MiR 100

Height: 543 / 900 mm

Length: 765 / 899 mm

Width: 450 / 585 mm

PERSPECTIVE SIDE / FRONT

